

分岐用

軽量ケーブルトラフ



片分岐

両分岐



片分岐

両分岐

ふた

ふた

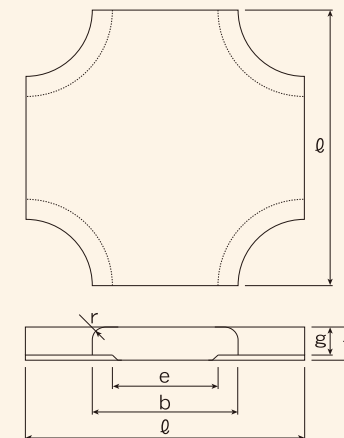
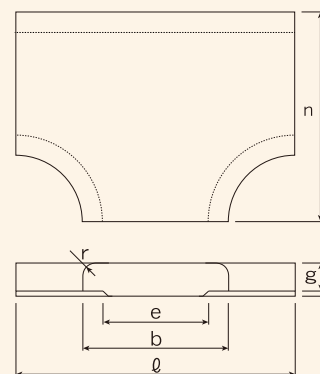

本体

本体

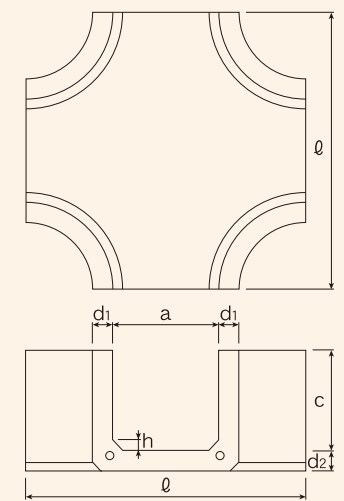
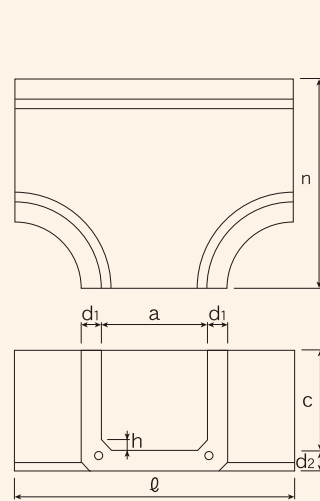

■ 寸法表

呼び名	寸法 (mm)											参考重量 (kg)						
	a	b	c	d1	d2	e	f	g	h	r	φ	n	片分岐			両分岐		
													本体	ふた	組	本体	ふた	組
軽 量 分 岐 用	K80	80	120	87		75						310	10.5	6.5	17	13	9	22
	K100	100	140	107	20	23	95	30	21	15	15	320	12	7	19	15	10	25
	K130	130	170		125							500	335	13	8	21	15.5	11.5
	K164	164	210	135	23	25	154	40	31	20		355	17	13	30	19	17	36
	K220	220	270	175	25	30	210	50	41	25	25	385	23	20	43	24.5	24.5	49
	K280	280	330	180			270					560	445	28.5	26.5	55	30	32
	K330	330	390	180	30	35	320					600	495	38	32	70	39	38
K450	450	510	235	30	35	440	700	605	55	48	103	52.5	54.5	107				